

ROTATING DISC VALVES

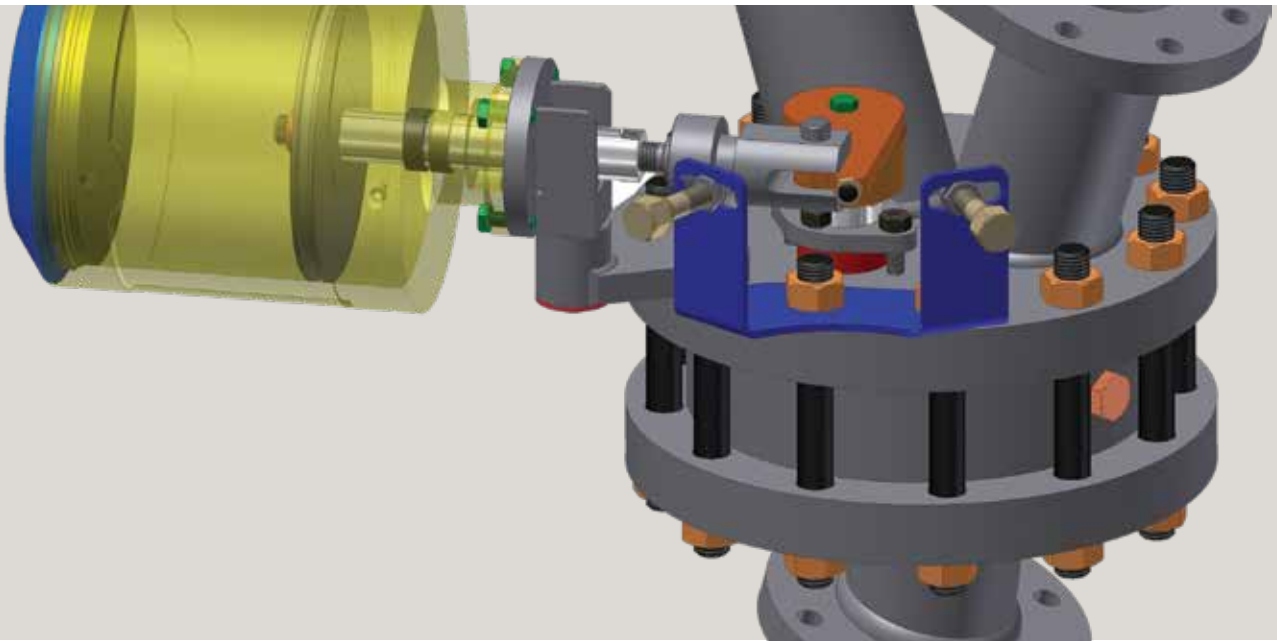

MITECH[®]

Local Expertise - World Class Solutions

ROTATING DISC VALVES

Long service life with reduced maintenance

ABOUT ROTATING DISC VALVES

The locally designed and manufactured Rotating Disc Valves feature a unique rotating/shearing disc which provides a self-lapping rotation and enhanced seat cleaning action which cuts through solids giving a long-lasting tight shut-off.

The metal-to-metal seating makes the valves abrasion resistant over a wide temperature range. Their high pressure capability, which is better than industry standards, allows the force to be distributed over a larger area resulting in reduced trim wear.

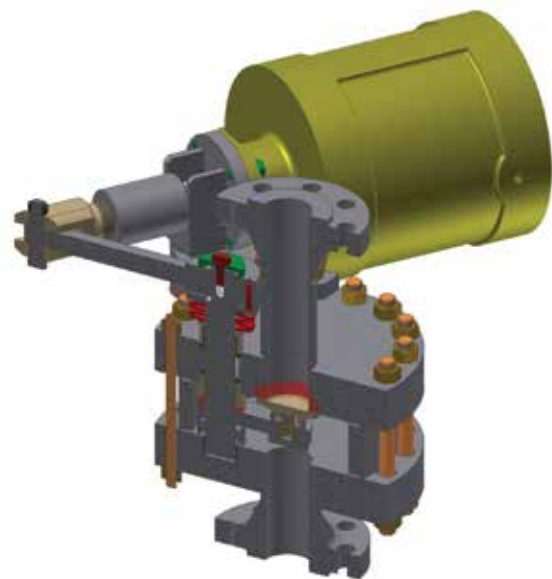

APPLICATIONS

- Steam
- Coke
- Fly Ash
- Flammable liquids
- Gases
- Sand
- Boiler water
- Abrasive or corrosive media

SUMMARY OF KEY FEATURES AND BENEFITS

Model	Key features	Key benefits	
	ROTATING DISC VALVES	Unique rotating shearing disc	Self lapping disc, enhanced seat cleaning action
	Metal to metal seating	Abrasion resistant, wide temperature range	
	Wide band seating	High pressure capability, better sealing than industry standard	
	Full port	Abrasion resistant, no obstruction to flow, minimal pressure drop	
	Rotating stem	Increased packing life, wide selection of actuators	
	Self draining body	Reduced chance of jamming due to material entrainment, stagnation and degradation	
	Body purge connections	Ability to flush valve cavity and internals while in operation	
	Repairable seat	Reduced inventory, less maintenance	
	Simplicity in design	Minimal parts, long service life	

VALVE TYPES

- Bulk Material Valves: Designed for pneumatic conveyancing of dry powdery media.
- Single Disc Valves: For applications where pressure and flow can only be from one side and mediums that do not compact.
- Double Disc Valves: For applications where pressure or flow can come from either side or for compacting mediums.
- Diverting Valves: For applications where flow is to be diverted from one line into another.

CONSTRUCTION

- Sizes: 12 mm - 600 mm
- End Connections: Screwed, Flanged, Socket and Butt Weld
- Body Material: Cast Iron / Ductile Iron, Carbon Steel, Stainless Steel, Weldable Alloys
- Packing / Seals: Grafoil or PTFE
- Disc / Seat Material: Stellite #6, Thyrodur
- Basis of Design: Vacuum to 65 mPa, ANSI Classes 150, 300, 600, 900, 1500, 2500
- Temperatures: -200°C to 800°C
- Actuators: Manual Lever, Manual Gear, Pneumatic, Hydraulic and Electric

SELF CLEANING

The openness of the valve body provides space for the product to be freely displaced by the lever arm and disc with each cycle. Fines cannot compact in small open areas and possibly jam components as is the case with other valve concepts.

Each time the valve opens to discharge the product, a vortex is caused by the eccentric body to port configuration. The settled media swirls, thereby cleaning the valve's interior.



MITECH

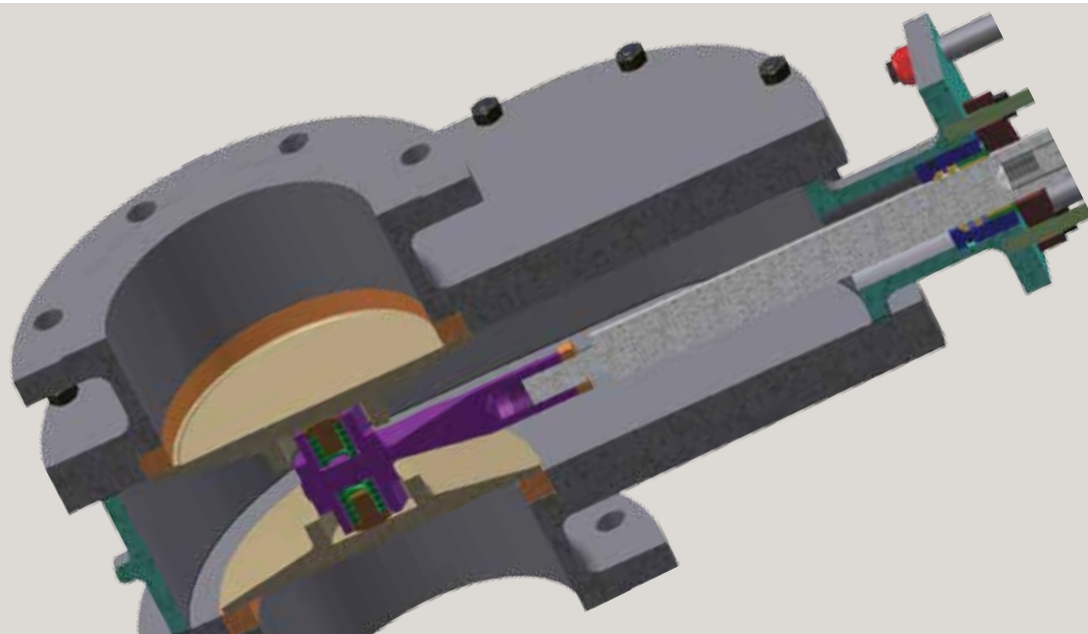

PSV Holdings Office Park
Corner Barbara and North Reef Roads
Elandsfontein
t: +27 (0)11 657 6066
f: +27 (0)11 657 6096
enquiries@mitech.co.za
www.mitech.co.za



MITECH[®]
Local Expertise - World Class Solutions